

SPARK[®]

HIGHBAY LIGHT

SPGK015-SERIES



IP66

FIVE-YEAR

5

WARRANTY

Aviation Aluminum LED High Bay



SPGK015 series LED High Bay Light has high-quality aviation aluminum(1060 Al metal sheet) for heat sink,UFO appearance design, light weight structure, beautiful and stylish, high temperature, corrosion resistance, suitable for a variety of harsh working environments..

Optional function: microwave induction and DALI / 0-10V / PWM optional dimming features.It is an excellent product for industrial and mining, factories, warehouses, stadiums, exhibition halls and other large space.

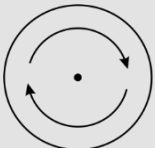

Dimmable
1-10V as standard



5 Years
Guarantee



High efficiency



For all industrial
applications



Microwave sensor
Detailed reference manual



10,000 Hours

Explosive View

DRIVER

IP66 High performance drive with 4KV surge protection embedded. The unique into 100,000hrs operating at 55 deg ambient temperature.



PCB+LED

Imported high efficiency LED, The whole lighting effect is as high as 170 lm/W.

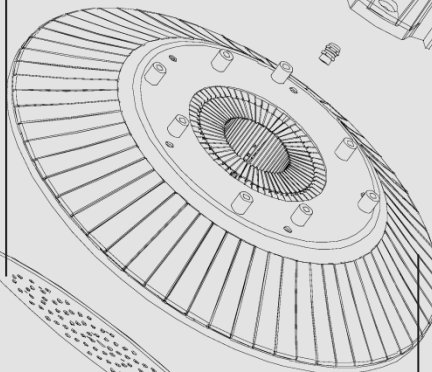
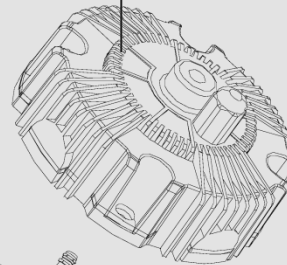

RADIATOR

High quality aviation aluminum profile lamp body, excellent heat dissipation performance.

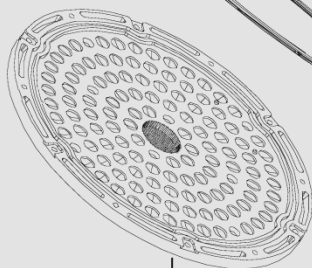

SEAL RING

One-piece silicon gasket are mechanically secured IP66 protection preventing moisture and dust.

LENS

High quality polycarbonate shatter proof diffuser provides assurances and safety in the work places with low UGR value.

Feature

High efficacy as always, up to 170lm/W

LED chip from US with high luminous efficiency, luminaire efficacy up to 170 lm / W, 40% energy saving than conventional LED high bay light, significantly reducing energy costs.

No Glare

Design of professional light distribution, effectively prevent glare, and provide better visual comfort.

Smart as always

0-10V / DALI / PWM intelligent dimming control optional, intelligent control brightness, less costs with much more energy-saving.

Optional microwave induction

The function of microwave induction is optional, which can make people switch off the lamp and reduce energy cost greatly..

Fashion shape design

UFO appearance design, lightweight structure, beautiful fashion, leading industrial lighting.

Application

Mining, factories, warehouses, stadiums, exhibition halls, workshops and other large high-altitude lighting case.



Specifications

Model No.	SPGK015-100	SPGK015-150	SPGK015-200
Rated Power	100W	150W	200W
Luminous Flux(lm)	13000/15000/17500	19500/22500/25500	26000/30000/34000
Luminous Efficiency (lm/W)	130/150/170 lm/W		
Beam Angle	60°/90°/120°		
CCT	5000K/5700K/6500K		
Power Factor	0.95		
Input Voltage	100-277VAC 50/60Hz		
Storage Voltage	-40°C ~ +80°C		
Working Temperature	-40°C ~ +50°C 10% ~ 90RH		
IP Rating	IP66		
N.W	2.08kg	2.95kg	2.95kg
G.W	3.25kg	4.15kg	4.15kg
Product Size	Φ260×170mm	Φ302×183mm	Φ302×183mm
Packing size	302X302X210mm	342X342X220mm	342X342X220mm
Installation Method	Hanging install/ Bracket install		

Outline Drawing (Unit:mm)

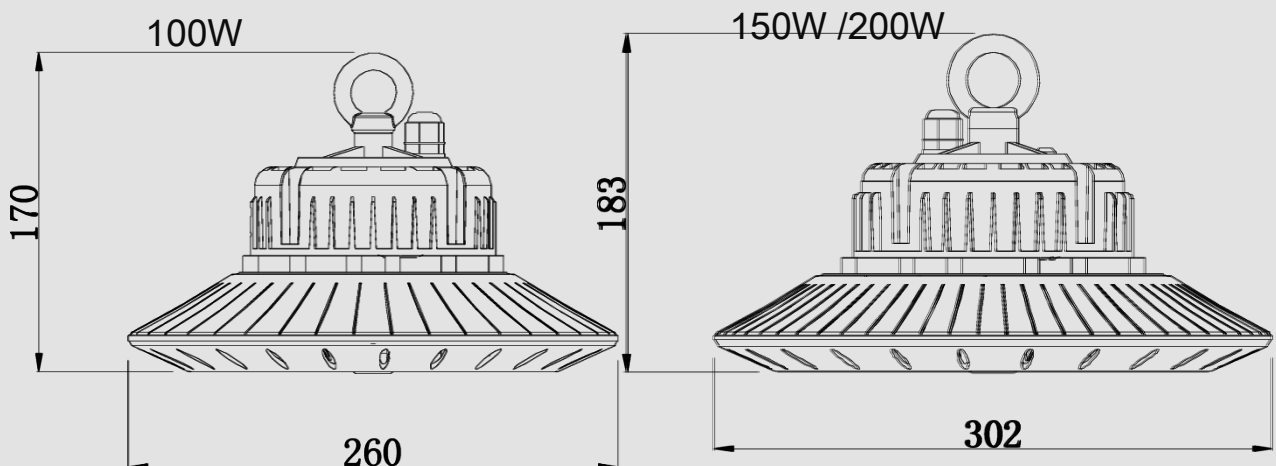

Photometric Diagrams

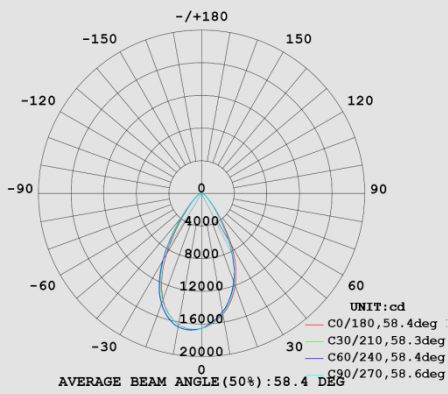

60°

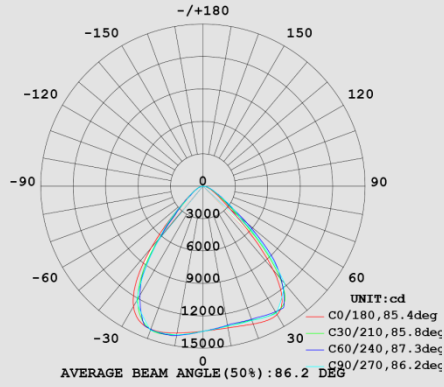

90°

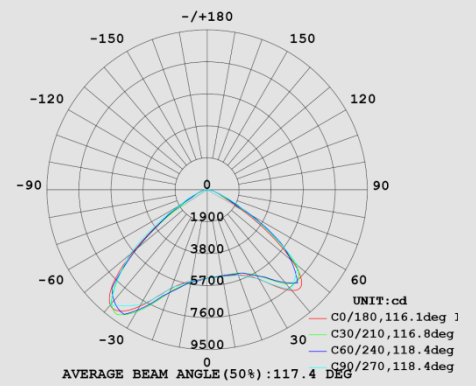

120°

Installation

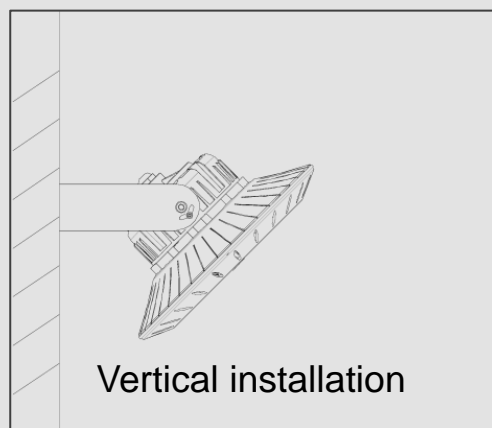
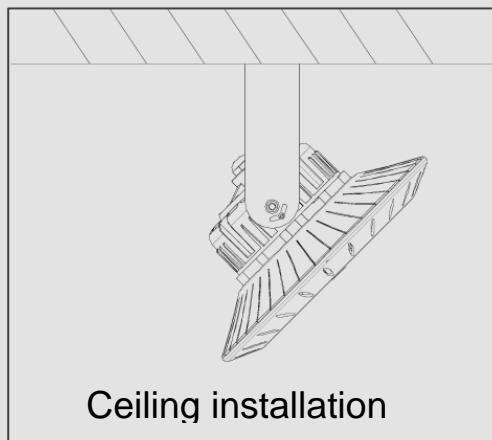
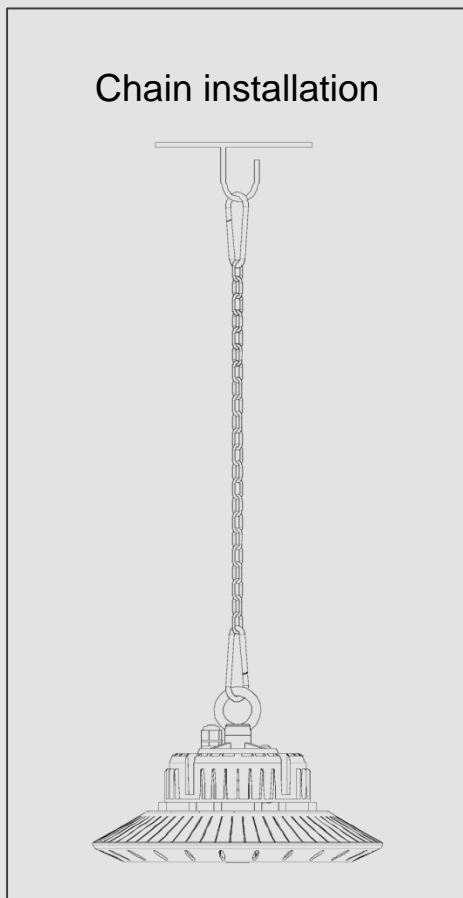

Packing

1. Packaging Sketch Map

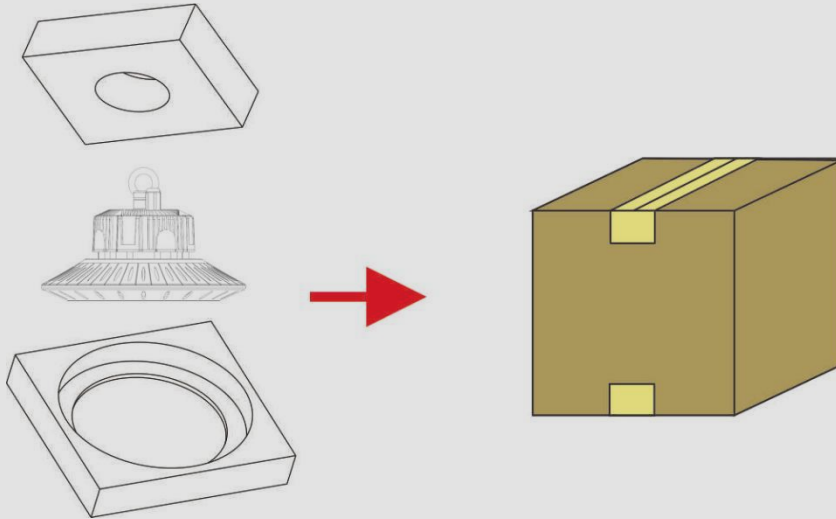

2. Product Labeling

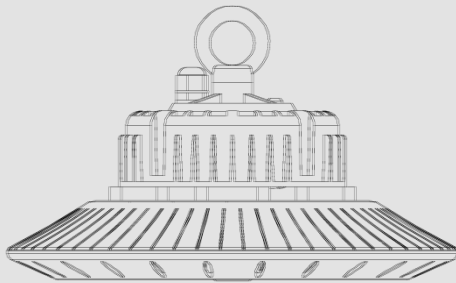

3. Mark Label



Shenzhen Spark Optoelectronics S&T Co., Ltd.

Headquarter

27th floor,Block A,Shenzhen International Innovation Center,1006

Shennan Rd.,Shenzhen,China

ZIP:518035

Tel : +86-755 8308 8855 +86-755 8390 4366

Fax: +86-755 8391 4431 +86-755 8390 4766

24-Hour Service Hotline: 400-6232311

E-mail: spark@spark-oe.com Web: www.sparkoe.com

Factory

Wanlida Industrial Park, Fuyuan 1st Road, Heping Village, Fuyong

Town, Baoan District, Shenzhen, China

ZIP: 518103

Tel: +86-755 2959 6112 Fax: +86-755 2959 6117